

Operating instructions

For the **COMPUTHERM DS2-20** type
magnetic dirt separators



Contaminants are always present in heating and cooling systems. They can accumulate over time and can cause clogging, failure, performance degradation, or noise. To prevent this, dirt must be separated from the system. The **COMPUTHERM DS2-20** magnetic dirt separator serves this purpose, with its design, filter and strong magnet, it effectively removes both magnetic and non-magnetic dirt from the heating/cooling systems, allowing the proper operation of the system and increasing its lifetime.

The product is easy to install and maintain. No need to replace seals or other parts during maintenance and cleaning. The magnetic dirt separators are much more efficient than conventional filters and require less maintenance.

The components of the product and the main advantages of its design:

1. A container with a filter to separate and collect dirt.
2. Removable strong magnet for easy cleaning.
3. Drain connection to remove dirt.
4. Threaded cover sealing of the drain connector.
5. Shut-off valve for easy draining of the product.

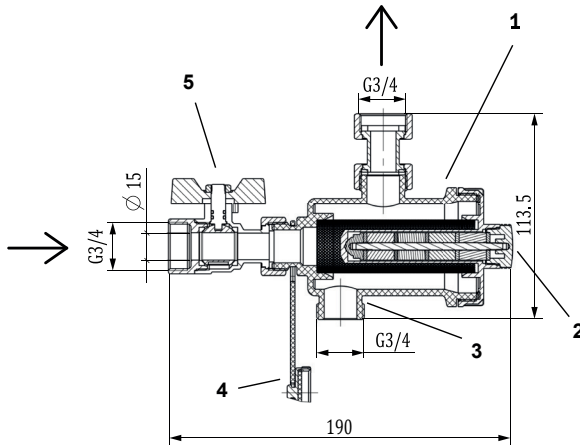

Installing the device:

Attention! If you're using a pacemaker, then special care must be taken while handling the magnetic dirt separator, similarly as with all strong magnetic products.

Attention! The strong magnet in the product can damage some electrical devices. Keep away from these devices to avoid damage.

Attention! Install the product in a dry place which is not exposed to frost and is easily accessible for maintenance.

Attention! For higher efficiency, the installation diameter of the dirt separator must match the pipe diameter of the system. The use of any adapter is not recommended.

Before installation, prepare a suitable location for the dirt separator in the heating/cooling system. Please note the product's connection dimensions. The product must be placed so that the dirt separator housing should stand horizontally and the drain connection should be located at the bottom of the

product. Make sure that the flow direction is the same as the flow direction indicated in the picture above. Install the dirt separator in the return branch before the heating/cooling device, if possible before the floor heating circulation pump. Before installation, close the ball valves of the product and the one before the heater/cooler device too, and open them only after installation.

Emptying the collected dirt and venting:

It is recommended to empty the accumulated dirt in the tank at regular intervals (at least once per heating/cooling season). Follow the steps below to remove dirt:

- Turn off the heating/cooling system so that the fluid does not flow in it.
- Close the ball valve connected to the product and the ball valve between the heating/cooling unit and the dirt separator.
- Unscrew the magnetic rod from the product and remove it until the end of the cleaning process.
- Unscrew the screw cap from the bottom of the product so that the dirty liquid can drain from the tank.
- Leave the drain connector open until the dirty water drains from the product, then screw the cap back on. If you find that not all dirt was removed from the product's housing, unscrew the metal closing element of the housing with the key included in the package, and clean it. After cleaning, screw back the metal closing element of the product housing.
- Place the magnetic bar back into the top of the product.
- Open the closed ball valves connected to the product and the heating/cooling system.
- If necessary, refill the heating/cooling system to achieve the correct water pressure.
- Turn the heating/cooling system on.

TECHNICAL DATA:

Size of connections:	3/4"
Maximum operating pressure of the heating circuit:	10 bar
Minimum operating temperature:	0 °C
Maximum operating temperature:	90 °C
Maximum flow rate:	76,7 l/min
K_{vs} :	4,8 m ³ /h
Magnetic strength:	9000 Gauss (neodymium magnet)
Housing material:	glass fiber reinforced nylon (PA66)
Tank volume:	200 ml
Weight:	700 g
It can be used in both heating and cooling systems	yes

Manufacturer: **QUANTRAX Ltd.**
Fülemüle u. 34., Szeged, H-6726, Hungary
Phone: +36 62 424 133 • Fax: +36 62 424 672
E-mail: iroda@quantrax.hu
Web: www.quantrax.hu • www.computherm.info

Country of origin: China

